

Low-Power Hall Switch

FEATURES

- Micro power consumption
- 2.4V to 5.5V battery operation
- Chopper Amplifier based design:
Insensitive to noise and offset caused by process variations, operating temperatures and mechanical stress
- Digital output
- Programmable output direction
- CMOS process
- Available in SIP-3L package

GENERAL DESCRIPTION

FH168 is a low-power integrated Hall switch designed to sense the applied magnetic flux density and give a digital output, which indicates the present condition of the magnitude sensed. One example of the applications is the on/off switch in cellular flip-phones.

The micro power design is especially suitable for battery-operated systems such as cellular phones or laptop computers, in which power consumption is one major concern. The typical power consumption of FH168 is below $10\mu\text{W}$ at 2.7V.

The magnetic switching points are precise and insensitive to process and temperature variations.

For FH168, the output will be at the "low" level if the applied magnetic flux density(North pole) is stronger than the switching threshold.

For detailed magnetic flux direction please refer to the figure.3

BLOCK DIAGRAM

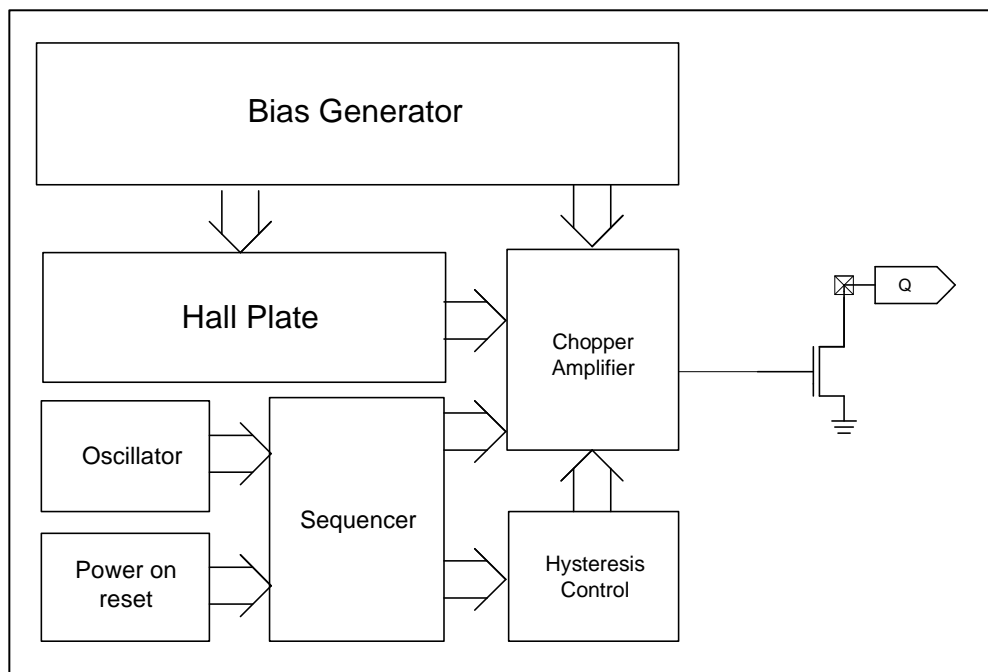

Figure.1

PIN CONNECTION

SIP-3L

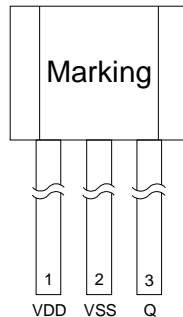

Figure.2

PIN DESCRIPTIONS

Name	I/O	Description
Q	O	Open Drain output
VDD	P	Positive supply
VSS	G	Ground

Legend: I=input, O=output, I/O=input/output, P=power supply, G=ground

2.0 FUNCTIONAL DESCRIPTIONS

Refer to the block diagram (Figure.1), FH168 is composed of the following building blocks:

- Bias generator

The bias generator provides precise, temperature and process insensitive current sources for both the Hall plate and the chopper amplifier. These current sources in turn guarantee proper operation of the chip and precise switching thresholds under all kinds of environments specified in the specification.

- Oscillator + Sequencer

The built-in oscillator provides the clock signal, which is taken by the sequencer to determine the periods of the operating phase and the stand-by phase. Typically the operating time is about 60us and the stand-by time is 150ms. Using such a clocking scheme, the average power consumption is almost equal to that in the stand-by phase, which is under 10μW at 2.7V.

- Power on Reset

Used to detect the power-up ramp and reset the digital circuits to attain correct operation as soon as the power is ready.

- Chopper Amplifier

To achieve a higher resolution the chopper amplifier structure is adopted in this design. Use of this structure dynamically removes both the offset and flicker noise at the same time.

- Hysteresis Control

This block determines the switching threshold of the Hall switch in different situations.

ABSOLUTE MAXIMUM RATINGS

Parameter	Conditions	Values		Unit
		min.	max.	
Ambient Operating Temperature	-	-40	85	°C
Storage Temperature	-	-40	150	°C
DC Supply Voltage	-	2.4	5.5	V
Supply Current	-	-1	2.5	mA
Magnetic Flux Density	-		unlimited	Gauss
Lead Temperature	10sec	-	260	°C

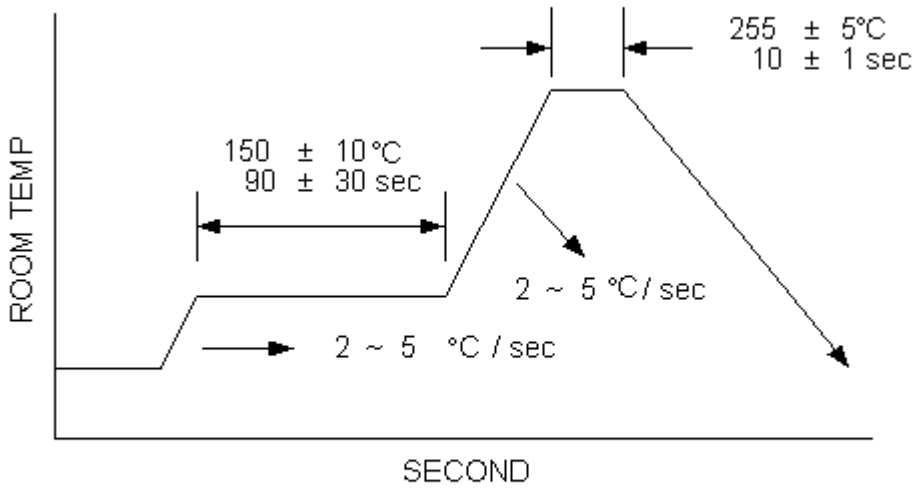

Soldering Condition

OPERATING CONDITIONS

Parameter	Conditions	Values			Unit
		min.	typ.	max.	
Supply Voltage	-	2.4	2.7	5.5	V
Output Voltage	-	-0.3	2.7	5.5	V
Ambient Temperature	-	-40	25	85	°C

ELECTRICAL CHARACTERISTICS

Parameter	Conditions	Values			Unit
		min.	typ.	max.	
Average Supply Current			3 ¹	20	μA
Average Supply Current (operating phase)			1.1 ¹		mA
Average Supply Current (stand-by phase)			2.5 ¹		μA
Output Saturation Voltage			0.1		V
Output Leakage Current			0.01		μA
Operating time			60		μs
Standby time			150		ms
Duty cycle			0.04		%

1. operating voltage 2.7V

MAGNETIC CHARACTERISTICS

Parameter	Conditions	Values			Unit
		min.	typ.	max.	
Operate Points (B _{OP})		15	25	35	G
Hysteresis		5	10	15	G

MAGNETIC FLUX DIRECTION

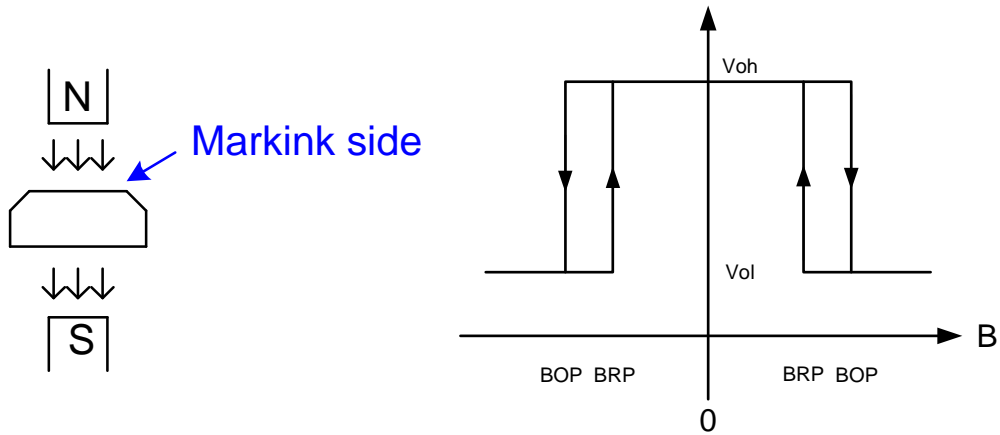

Figure. 3

TYPICAL CHARACTERISTICS

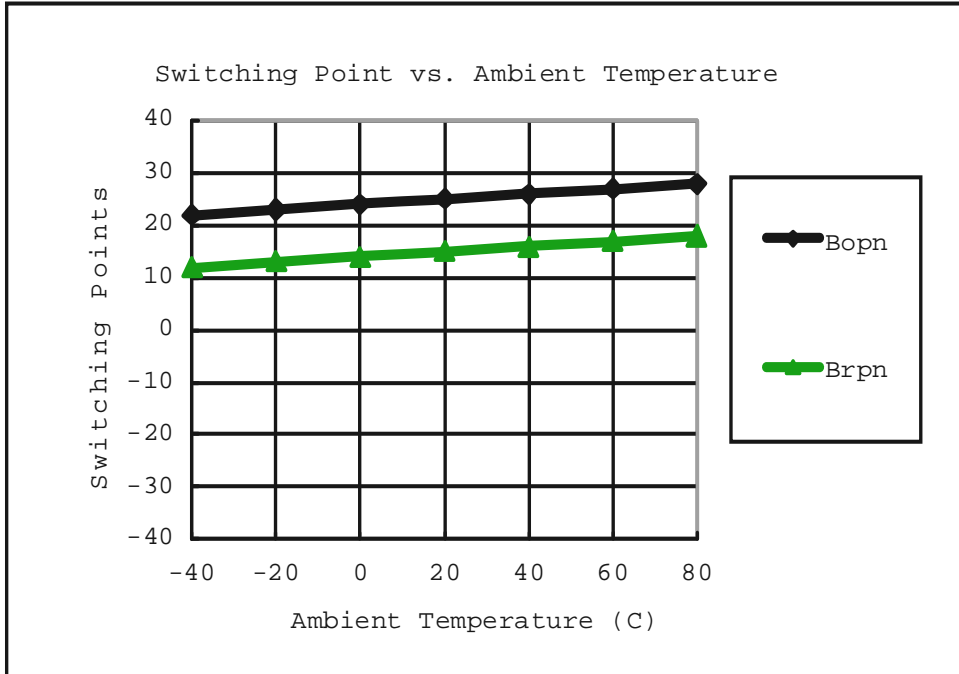

Figure.4 Magnetic Switch Points Versus Ambient Temperature (VDD=2.7V)

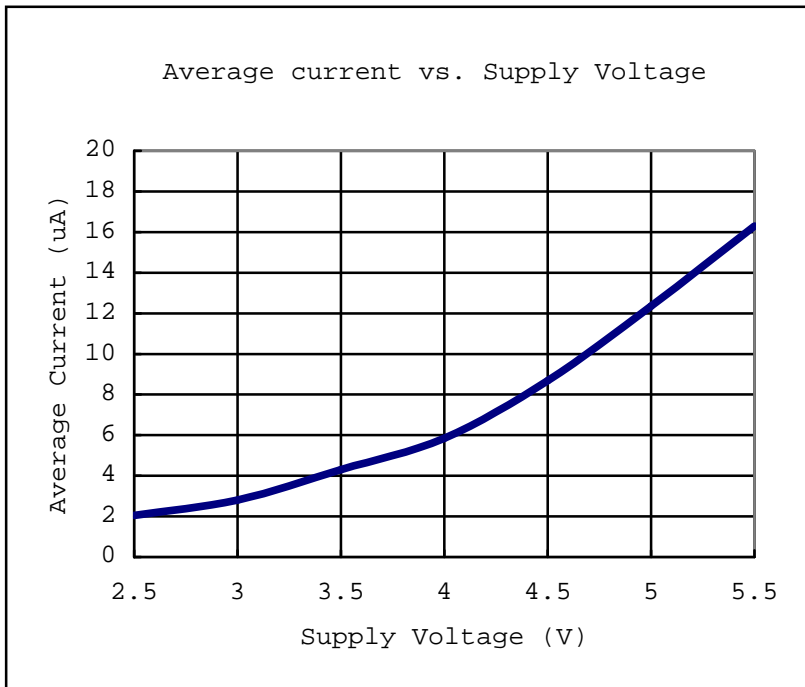

Figure.5 Average Current Versus Supply Voltage (Ta=25C degree)

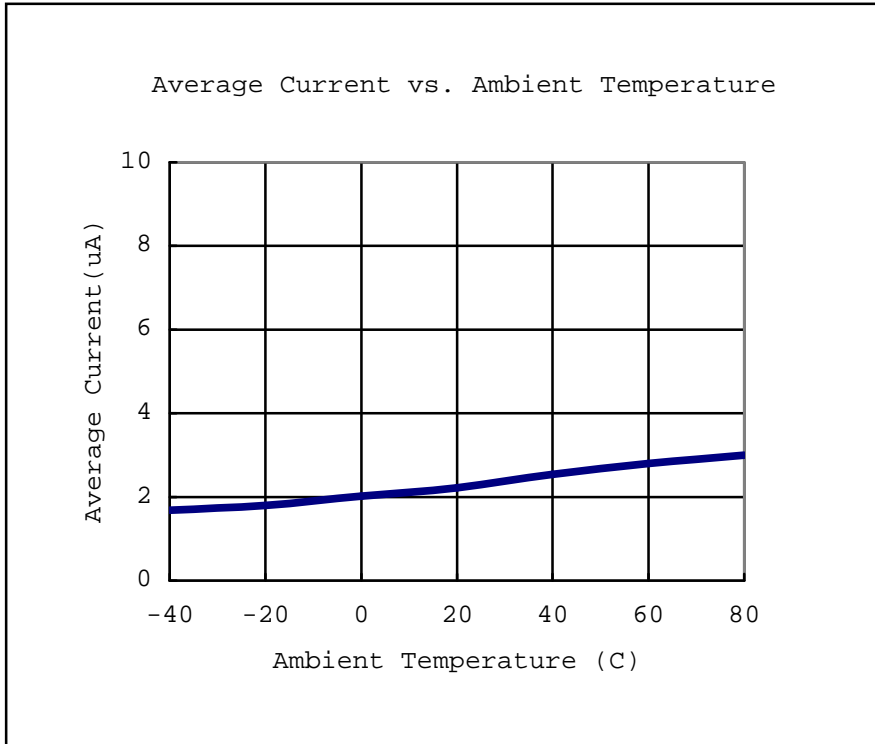
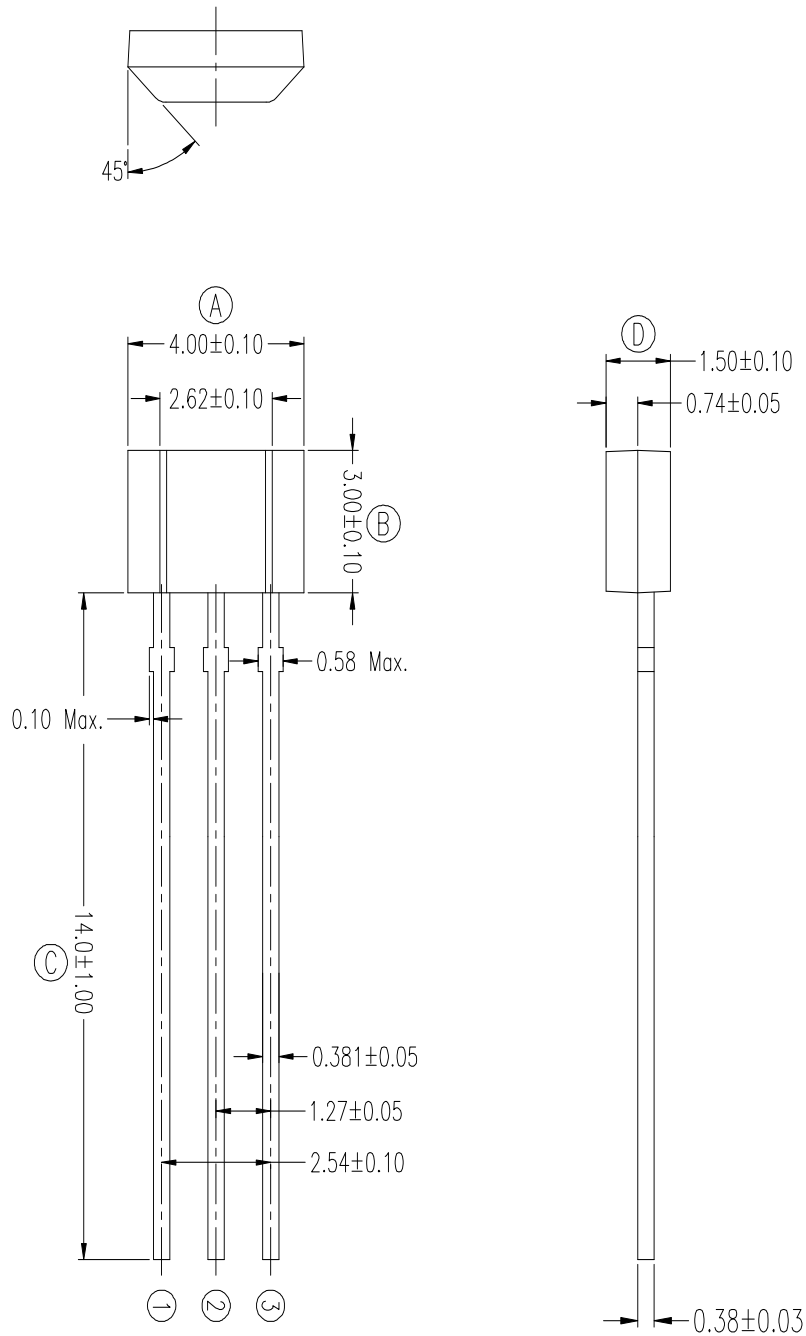

Figure.6 Average Current Versus Ambient Temperature (VDD=2.7V)

PACKAGE DIMENSION

Unit : MM

SIP-3L



Unit:mm

APPLICATION REFERENCE

SIP-3L

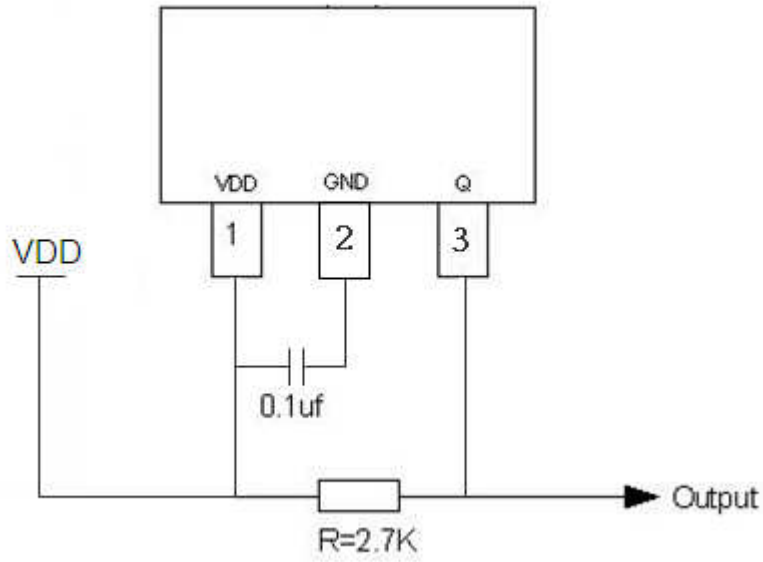

IC DATE CODE DISTINGUISH

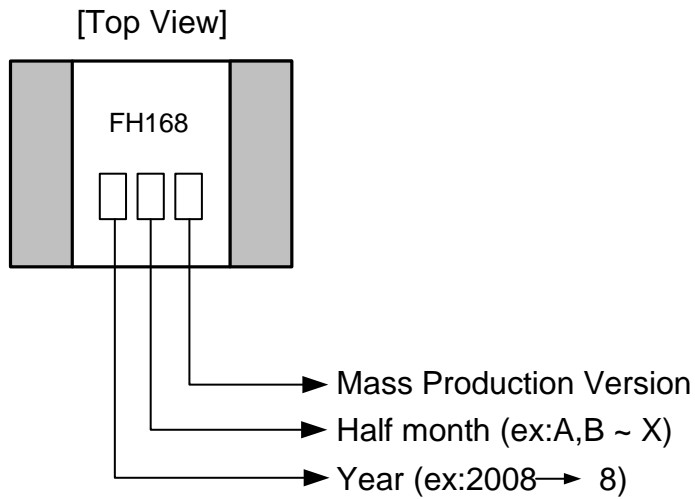

ORDER INFORMATION

Part Number	Operating Temperature	Package	Description	MOQ
FH168	-20 °C to +105 °C	SIP-3L	±25G (B)	1,000ea